

Water Tank MWT-300

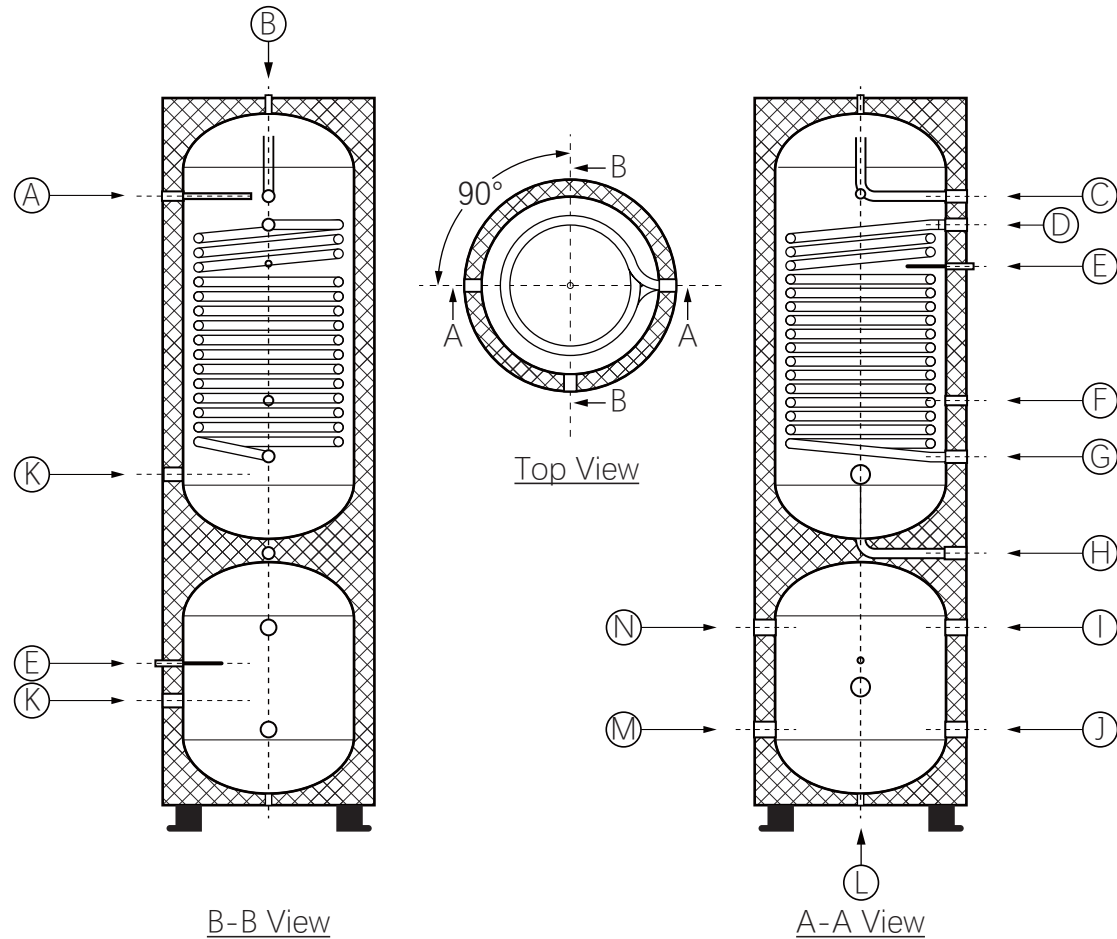

Pressurized Water Tank
 Model: MWT-300
 Capacity: 200+80Liter
 Max. working pressure: 8 bar
 Max. hot water temp: 85°C
 Coil heat exchanger: SUS316L
 Coil diameter: 25mm
 Coil length: 20m

No.	Connection Name	Specification	No.	Connection Name	Specification
A	Magnesium Anode	G3/4"-F	H	Cold water inlet	G1"-F
B	For air vent	G1/2"-F	I	A/C water out	G1-1/4"-F
C	Hot water out	G1"-F	J	A/C water inlet	G1-1/4"-F
D	Heat exchanger coil inlet	G1"-F	K	For electric heater	G1-1/2"-F
E	Probe tube	G1/2"-F	L	Drainage	G1/2"-F
F	Hot water cycling	G3/4"-F	N	Heat source water outlet	G1-1/4"-F
G	Heat exchanger coil outlet	G1"-F	M	Heat source water inlet	G1-1/4"-F

1	Initial release 1-20	20230217	-	-	-
Rev.	Detail	Date	DRN	DSGN	CHKD
Part Name: 300L Dual inner tank water tank					
Part No.: MWT-300 (DUAL)					

Water Tank MWT-200

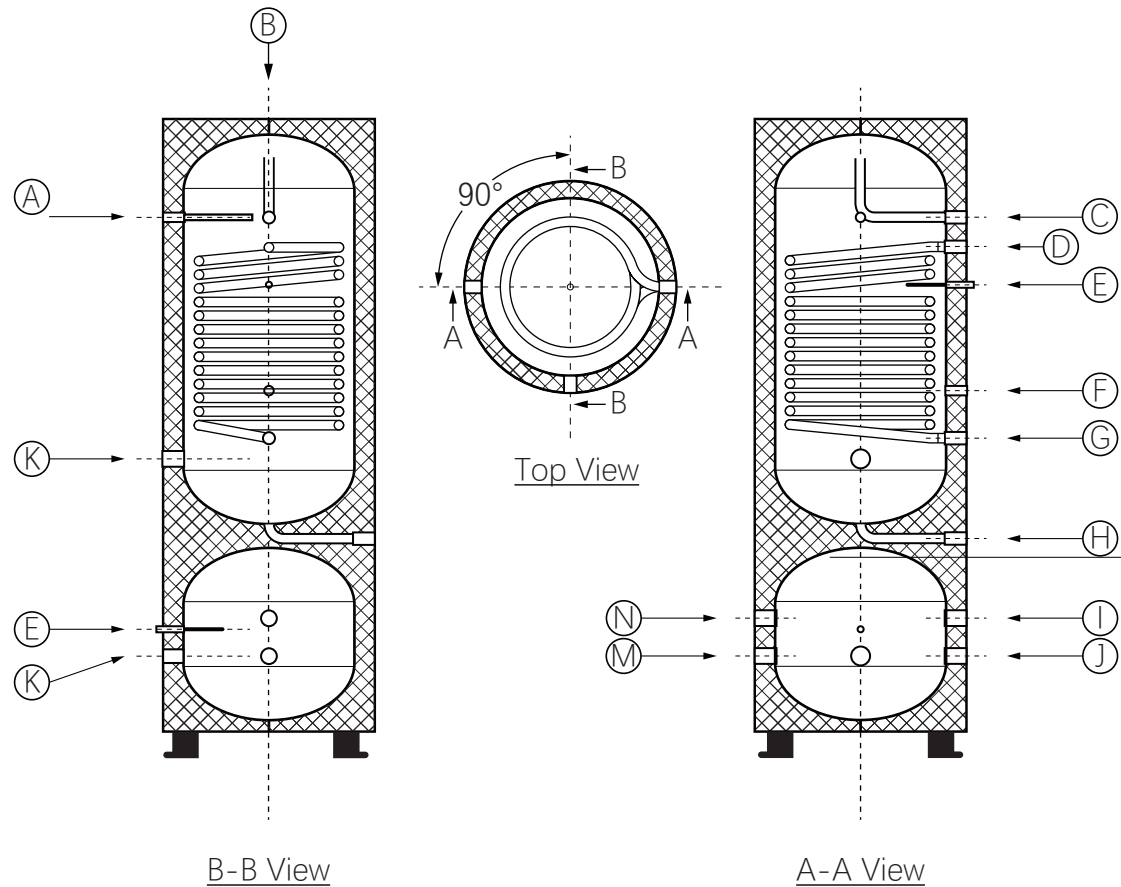

Pressurized Water Tank
 Model: MWT-200
 Capacity: 150+30Liter
 Max. working pressure: 8 bar
 Max. hot water temp: 85°C
 Coil heat exchanger: SUS316L
 Coil diameter: 25mm
 Coil length: 15m

No.	Connection Name	Specification	No.	Connection Name	Specification
A	Magnesium Anode	G3/4"-F	H	Cold water inlet	G1"-F
B	For air vent	G1/2"-F	I	A/C water out	G1-1/4"-F
C	Hot water out	G1"-F	J	A/C water inlet	G1-1/4"-F
D	Heat exchanger coil inlet	G1"-F	K	For electric heater	G1-1/2"-F
E	Probe tube	G1/2"-F	L	Drainage	G1/2"-F
F	Hot water cycling	G3/4"-F	N	Heat source water outlet	G1-1/4"-F
G	Heat exchanger coil outlet	G1"-F	M	Heat source water inlet	G1-1/4"-F

1	Initial release 1-20	20230217	-	-	-
Rev.	Detail	Date	DRN	DSGN	CHKD
Part Name: 200L Dual inner tank water tank					
Part No.: MWT-200 (DUAL)					